



# Sludge Thickening System on Trailer

## SLG-F100-T

Our packaged sludge thickening system delivers a compact and high-performance solution for municipal and industrial wastewater treatment facilities. Engineered for efficiency and operational reliability, the system is fully integrated on a trailer, enabling rapid deployment and requiring minimal on-site infrastructure.



### Key Features:

- **SLG® Pretreatment System.**  
At the core of the solution is Orege's patented SLG® process, designed to significantly enhance solid-liquid separation efficiency.
- **FLOSEP® Thickener**  
A high-efficiency rotary drum thickener engineered to exploit the improved rheology of SLG®-treated sludge, enabling superior thickening performance.
- **Precision Pumping**  
The system includes progressive cavity pumps for both sludge feed and thickened sludge discharge, ensuring stable, low-pulsation flow across all stages.
- **Integrated Polymer Management**  
A dedicated polymer preparation and dosing unit ensures accurate, consistent polymer delivery for effective flocculation.
- **Smart Control System**  
All system operations are managed by a centralized Siemens PLC with HMI, providing intuitive control and process automation.
- **Remote Diagnostics and Support**  
Equipped with an EWON module, the system supports real-time remote monitoring and troubleshooting.

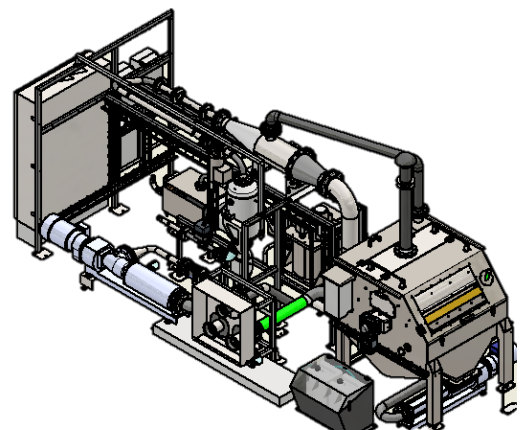
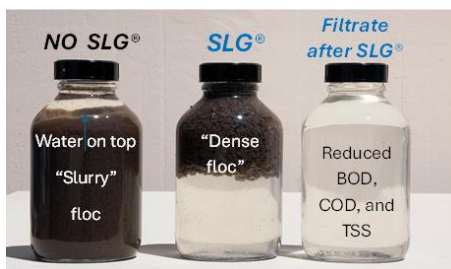

**Ideal for both municipal and industrial wastewater facilities**, this plug-and-play system minimizes footprint, accelerates installation, and delivers reliable, high-efficiency sludge treatment.

Also available in skid-mounted and 20' container configurations.

[www.orege.com](http://www.orege.com)

*Subject to change without prior notice. Information is for guidance only.*



## Technical Specifications

### General

Container Type	Trailer
Dimensions (Transport)	L7950 x W2700 x H3250 mm
Side openings	Goldwing doors, L4000 x H1900 mm
Tare weight	Approx. 3 500 kg
Foundation Requirement	Flat, level concrete slab or industrial flooring
Environmental	Avoid areas prone to high wind exposure

### Capacity & Performance

System Capacity	15 – 25 m <sup>3</sup> /h
Sludge Inlet Concentration	0.5 - 4%DS
Thickened Sludge Output	6 - 8%DS and more depending on the sludge and site constraints

### Recommended Operating Conditions

Temp. Range	5–45°C
-------------	--------

### Main Components

SLG® system	Orege's proprietary sludge pretreatment
FLOSEP®	Orege's proprietary solid-liquid separator
Air blower	Rotary claw blower, Pressure: up to 2.2 bars
Inlet Sludge Pump	Progressive cavity pump, Flow: 5–25 m <sup>3</sup> /h, Pressure: up to 6 bars, VFD controlled
Thickened Sludge Pump	Progressive cavity pump with integrated hopper, Flow: 3–10 m <sup>3</sup> /h, Pressure: up to 6 bars, VFD controlled
Polymer System	Polymore midi 160-24 + 25L polymer box
Control System	Integrated automation with mounted HMI (Siemens), Profinet communication
IIoT data gateway	Enable remote diagnostics and support

### Hydraulic connections

Sludge Inlet	Flange DN100 PN10/16
Thickened Sludge Outlet	Flange DN80 PN10/16
Filtrate Outlet	Flange DN100 PN10/16
Wash Water Inlet	DN25 Symmetrical half-couplings with lock
Clean Water Inlet	DN25 Symmetrical half-couplings with lock

### Power

Power supply	400V AC 50Hz, 3pH+N+PE, TN-S
Incomer rating	63A
Control Voltage	24V DC

